

FLAP SPAR HINGE OUTER

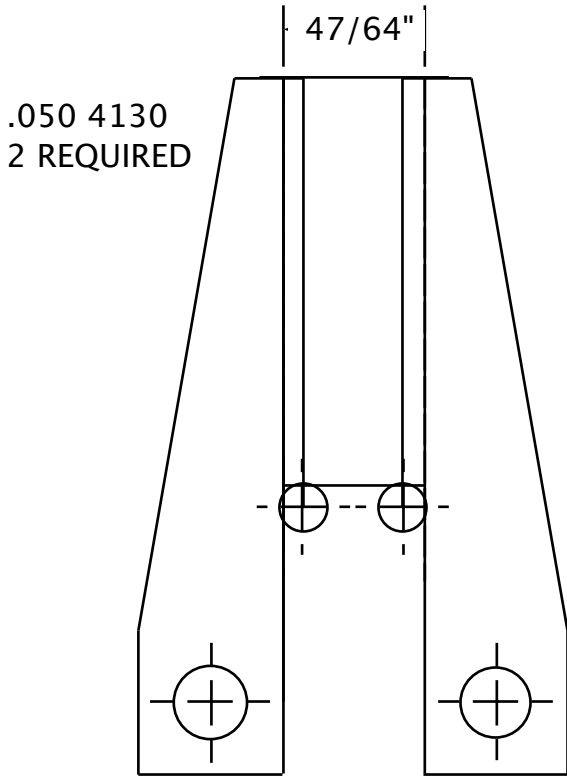

FLAP SPAR HINGE INNER

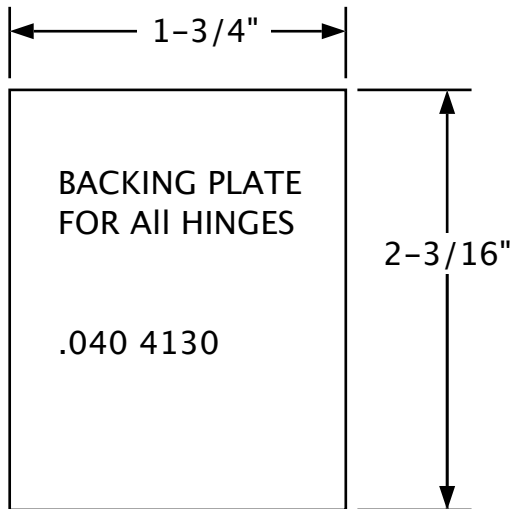
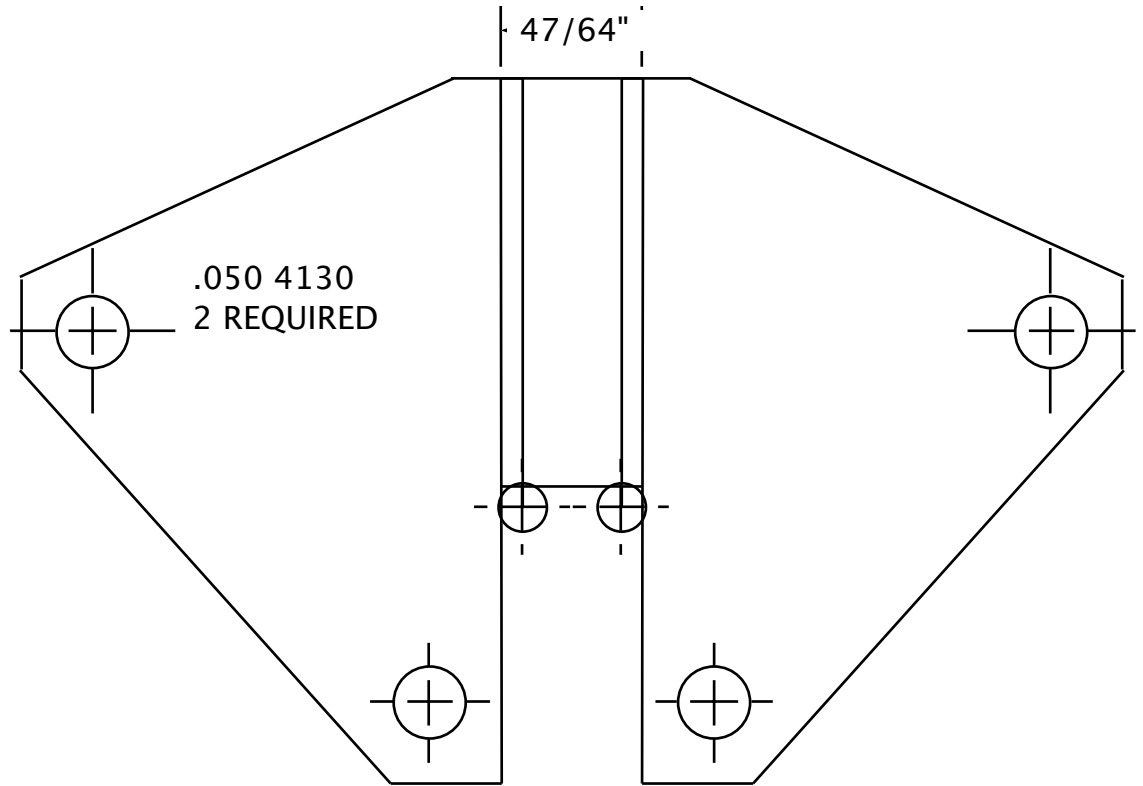

AILERON SPAR HINGE

3/8 x .065 4130
REAMED FOR 1/4"
CLEVIS PIN

Drill for bushing to be
welded. remove center
of bushing after welding
for alignment.

